

4000 Series TEMPERING OVENS

Microwave Heating & Tempering Systems



Temper your product in minutes instead of days.

ALLOWS TEMPERING ON DEMAND

Simple Efficient Precise Flexible

Microwaves offer many benefits to your operation. A tempering system eliminates the need for tempering rooms and multiple handling sequences. It provides the opportunity to improve the quality of your product and maximize yields by minimizing drip loss. Microwave tempering allows for precise control of product temperatures, ensuring they are within the required limits for subsequent slicing, grinding, forming, or molding. Your microwave tempering system will be customized to meet your specific requirements and facility layout. A multiple chamber layout allows for even greater control over your final results.

Safety

Interlocking access doors on the transmitters, process ovens, and passive microwave suppression tunnels meet applicable government safety standards for operation.



Belt System

A 24 inch wide positive drive, articulated belt of microwave transparent material moves continuously through the oven.



Sanitation

The entire oven is constructed of stainless steel and rated for full washdown.

FLEXIBLE INSTALLATION CUSTOM DESIGN

AMTek takes your installation requirements and provides a complete system layout, detailing oven location, utility requirements, and location within your facility. We can integrate optional add-on equipment into your design and layout as well.

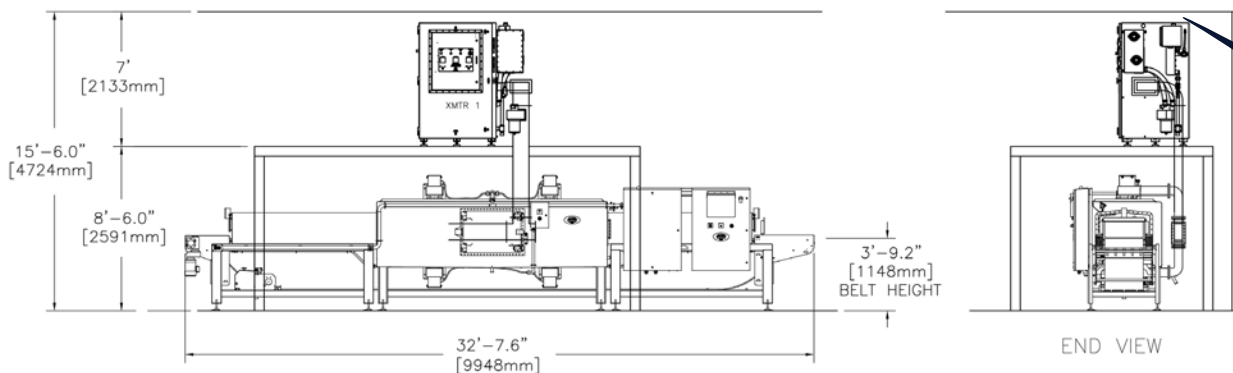

We know how important it is for your system to be up and running at all times. For that very reason, AMTek carries a full line of spare parts for all your microwave system needs. You will find that we are determined to provide you with the parts you need, when you need them.